



IRIS Holland techniek B.V.

Because we can

Advies • Lifttechniek • Ontwerp

Fermator
AUTOMATIC DOORS FOR LIFTS



WECO
Elevator Products



SCHAEFER 



Because we can

Advies • Lifttechniek • Ontwerp

Global presence



9 Manufacturing Hubs
5 Distribution Centers
33 Authorized Distributors



IRIS Holland techniek B.V.

Because we can

Advies • Lifttechniek • Ontwerp





IRIS Holland techniek B.V.

Because we can

Advies • Lifttechniek • Ontwerp





IRIS Holland techniek B.V.

Because we can

Advies • Lifttechniek • Ontwerp

EN 81-20 AND EN 81-50

Fermator

AUTOMATIC DOORS FOR LIFTS



Because we can.

Advies • Lifttechniek • Ontwerp

EN 81-20 AND EN 81-50, NEW EUROPEAN STANDARDS FOR LIFTS

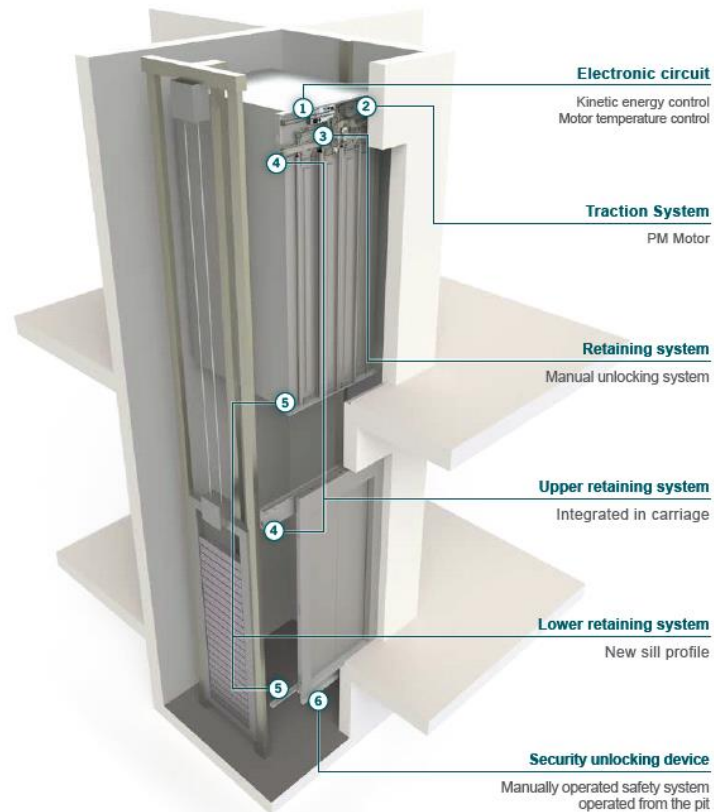



GROOTSTE VERANDERINGEN

1: PANELEN EN KOZIJNEN WORDEN VERSTEVIGD UITGEVOERD

1a: Hierdoor is de nieuwe ondergeleiding ontstaan

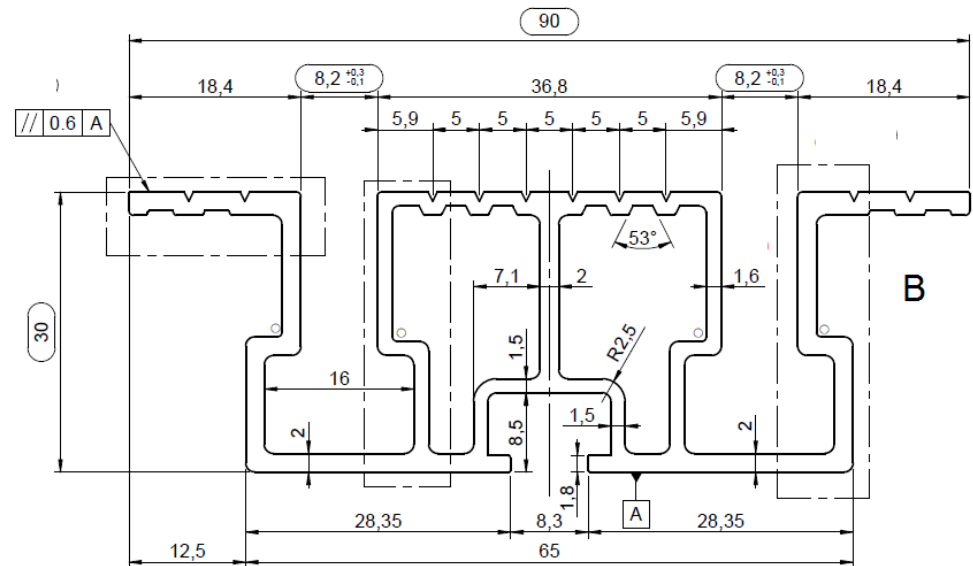
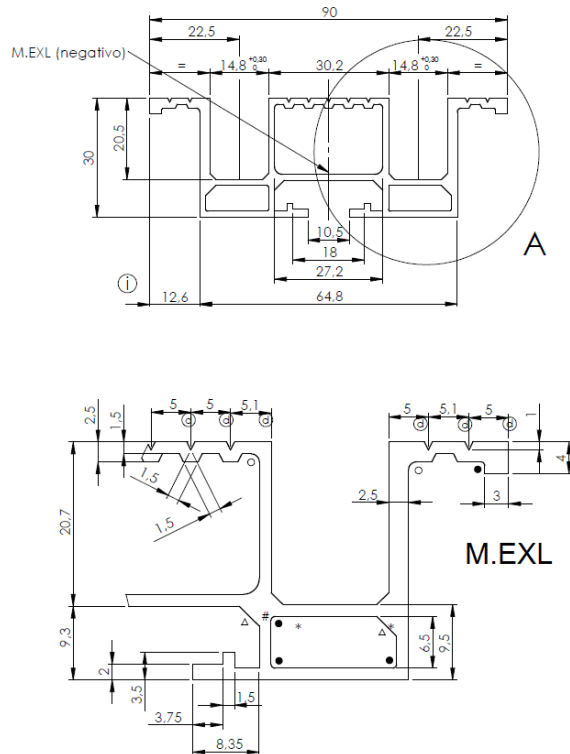



IRIS Holland techniek B.V.

Because we can

Advies • Lifttechniek • Ontwerp

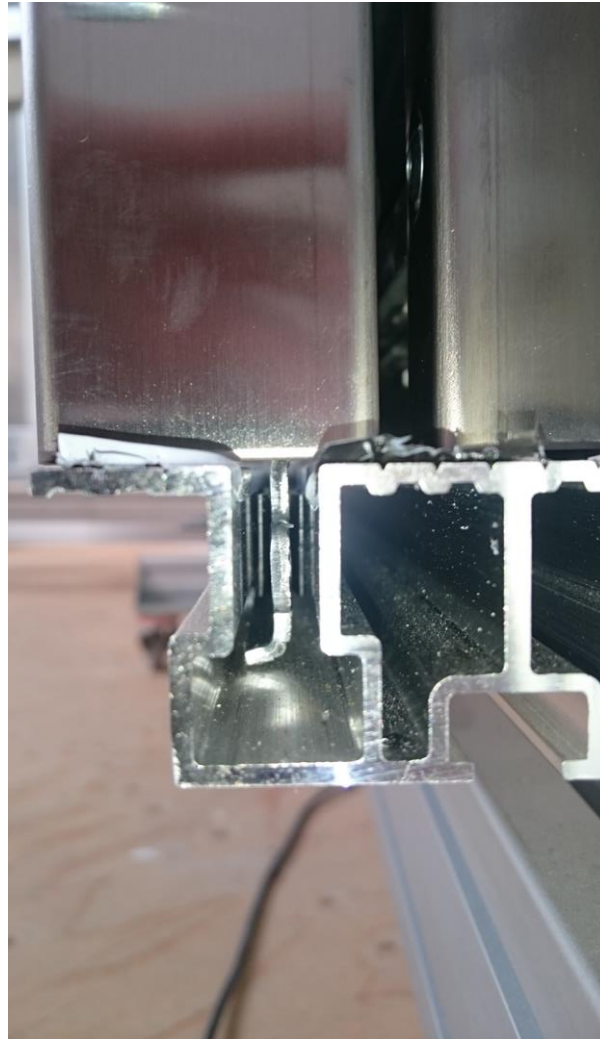



2: Ontgrendelschaats wordt met "lock" uitgevoerd. De CDL "car door lock"

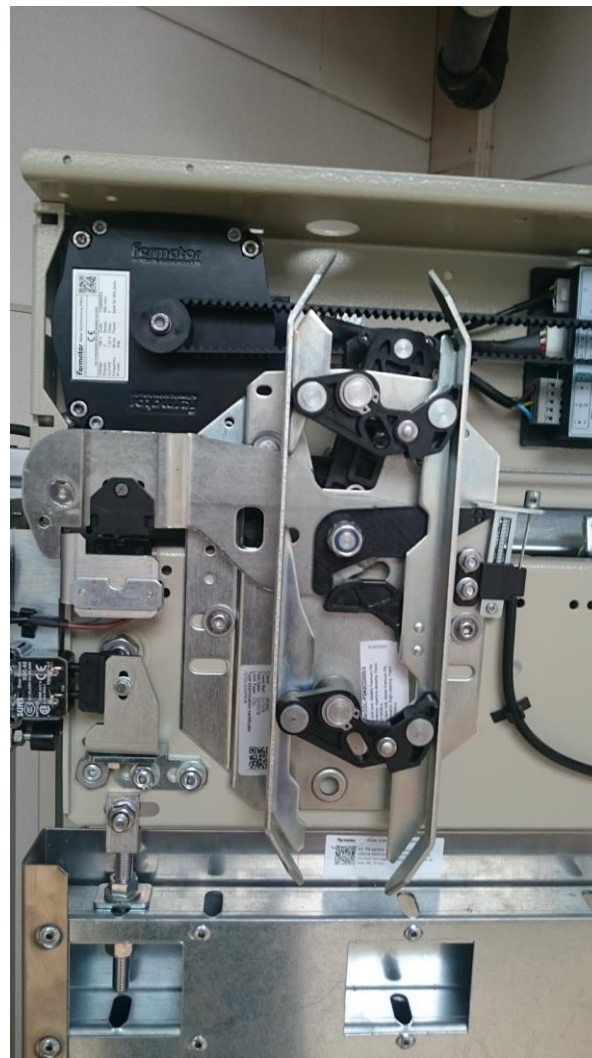
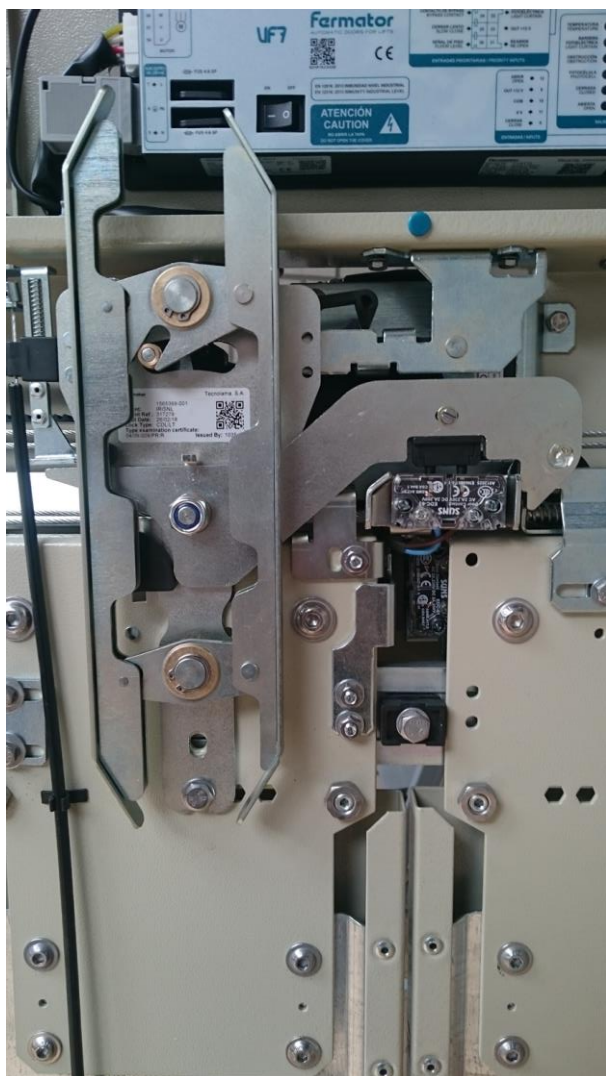



Because we can.

Advies • Lifttechniek • Ontwerp



3: Deurregeling VF 7 en de PM motor

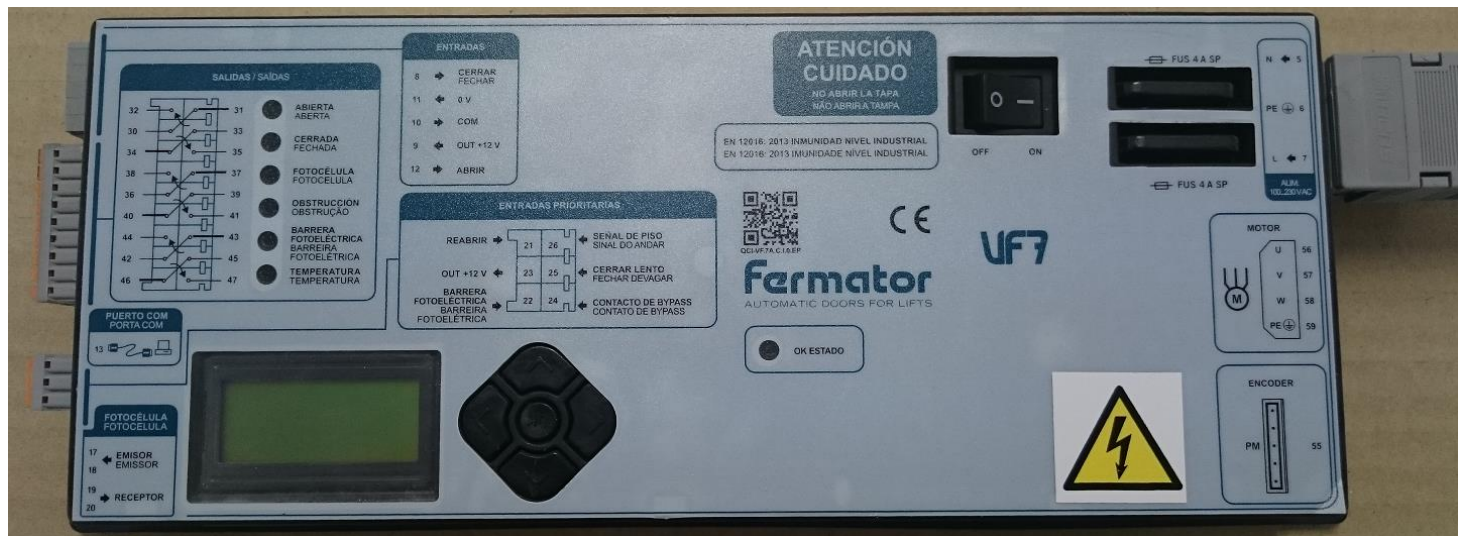



IRIS Holland techniek B.V.

Because we can

Advies • Lifttechniek • Ontwerp

Fermator
AUTOMATIC DOORS FOR LIFTS



WECO
Elevator Products



SCHAEFER 